

**Перус**<sup>RF</sup>

CUTTING TECHNOLOGIES



SOLUCIONES integrales de corte

SOLUTIONS intégrales de coupe

Integral cutting SOLUTIONS

SOLUÇÕES integrais de corte

## ¿Buscas soluciones de corte? Las tenemos todas

Gracias a nuestro departamento de I+D+i de última tecnología y a un contacto continuo con las necesidades del mercado, contamos con una de las gamas más completas e innovadoras de herramientas de corte que existen; más de 500 artículos diferentes y 15.000 referencias en stock.

## A la recherche de solutions de coupe ? Nous les avons toutes

Grâce à notre département R+D+i équipé des dernières technologies et à une écoute permanente des besoins du marché, nous disposons de l'une des gammes les plus complètes et innovantes d'outils de coupe, soit plus de 500 articles différents et 15 000 références en stock.



## Looking for cutting solutions? Look no further.

Thanks to our R&D&I department equipped with the latest technology, and being in constant contact with market needs, we have one of the most complete and innovative cutting tools that exists; over 500 different articles and 15,000 stock references.

## Procura soluções de corte? Temo-las todas

Graças ao nosso departamento de I+D+i de última tecnologia e a um contacto contínuo com as necessidades do mercado, contamos com uma das gamas mais completas e inovadoras de ferramentas de corte que existe; mais de 500 artigos diferentes e 15.000 referências em stock.

## CALIDAD GARANTIZADA

Más de 60 años de experiencia como fabricante, unidos a nuestros modernos medios técnicos y humanos, nos permiten garantizar máxima calidad en todas y cada una de nuestras herramientas.

Para ello controlamos minuciosamente todos los factores que hacen de una herramienta como Hepyc todo un referente de calidad:

- **MATERIALES DE FABRICACIÓN:** Gracias a un proceso productivo, que combina aceros de la máxima calidad (M2, M35, M42, M51, ASP, Metal duro) y el tratamiento térmico adecuado, conseguimos dotar a nuestras herramientas de la estructura metalográfica necesaria para obtener un rendimiento óptimo sobre cada material.
- **RECUBRIMIENTOS:** Para conseguir una mayor resistencia al desgaste y alargar la vida útil de la herramienta, la dotamos de recubrimientos de última generación tales como: TiN, TiALN, TiCN, CrN, ALCrN.
- **GEOMETRÍAS:** Nuestro departamento de ingeniería e I+D+i desarrolla las geometrías de corte adaptadas a las necesidades específicas de mecanización. Diferentes geometrías de ángulos de corte, hélices, entradas, tolerancias etc.. que hacen de cada herramienta la más óptima para el trabajo a realizar.

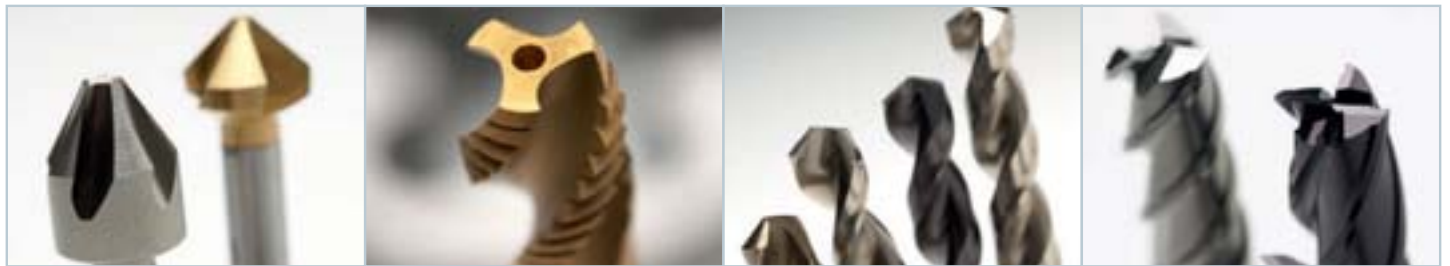

## GUARANTEED QUALITY

Over 60 years manufacturing experience, combined with modern technical and human resources, mean we can guarantee maximum quality for each and every one of our tools.

To do so we precisely control all of the factors that make Hepyc tools a point of reference in terms of their quality:

- **MANUFACTURING MATERIALS:** Thanks to a manufacturing process that combines top quality steels (M2, M35, M42, M51, ASP, hard metal), and adequate thermal treatment, we are able to provide our tools with the necessary metallurgical structure to obtain maximum performance from each material.
- **COATINGS:** We use latest generation coatings to provide greater wear resistance and extend tool life, such as TiN, TiALN, TiCN, CrN and ALCrN.
- **GEOMETRIES:** Our engineering and R&D&I department develops cutting geometries adapted to specific machining needs. Different cutting angle geometries, propellers, entries, tolerances, etc. that optimise each tool for the work at hand.

## QUALITÉ GARANTIE

Nos moyens techniques et humains modernes, adossés à nos plus de 60 années d'expérience comme fabricant, nous permettent de garantir la plus haute qualité sur tout et chacun de nos outils.

C'est pourquoi nous contrôlons minutieusement les divers facteurs qui font de l'outil Hepyc un référent en termes de qualité :

- **MATÉRIAU DE FABRICATION :** grâce à un processus de fabrication qui combine les aciers de la meilleure qualité (M2, M35, M42, M51, ASP, métal dur, etc.) et le traitement thermique approprié, nous parvenons à donner à nos outils la structure métallographique nécessaire pour obtenir un rendement optimal sur chaque matériau.
- **REVÊTEMENT :** afin de doter l'outil d'une meilleure résistance à l'usure et de prolonger sa vie utile, nous utilisons des revêtements de dernière génération : TiN, TiALN, TiCN, CrN, ALCrN.
- **GÉOMÉTRIE :** notre bureau d'études développe les géométries de coupe adaptées aux besoins spécifiques d'usinage. Des géométries qui s'appliquent tant aux angles de coupe qu'aux hélices, entrées, tolérances, etc..., qui font de chaque outil celui qui convient le mieux au travail à réaliser.

## QUALIDADE GARANTIDA

Mais de 60 anos de experiência como fabricante, juntamente com os nossos modernos meios técnicos e humanos, permitem-nos garantir máxima qualidade em todas e cada uma das nossas ferramentas.

Para isso, controlamos minuciosamente todos os factores que fazem de uma ferramenta como a Hepyc toda uma referência de qualidade:

- **MATERIAIS DE FABRICO:** Graças a um processo de produção, que combina aços da máxima qualidade (M2, M35, M42, M51, ASP, Metal duro) e o tratamento térmico adequado, conseguimos conferir às nossas ferramentas a estrutura metalográfica necessária para obter um rendimento óptimo sobre cada material.
- **REVESTIMENTOS:** Para conseguir uma maior resistência ao desgaste e prolongar a vida útil da ferramenta, cobrimo-la de revestimentos de última geração, tais como: TiN, TiALN, TiCN, CrN, ALCrN.
- **GEOMETRIAS:** O nosso departamento de engenharia e I+D+i desenvolve as geometrias de corte adaptadas às necessidades específicas de mecanização. Diferentes geometrias de ângulos de corte, hélices, entradas, tolerâncias etc. que tornam cada ferramenta a mais perfeita para o trabalho a realizar.











# TALADRADO / PERÇAGE / DRILLING / PERFURAÇÃO





Brocas con mango cilíndrico cortas / Forets à queue cylindrique courtes / Short straight shank drill-bits / Brocas com manga cilíndrica curtas (DIN 338)

1101	HSS	DIN338N				800 N/mm <sup>2</sup>
1101/1	HSS	DIN338N				800 N/mm <sup>2</sup>
1104	HSS	DIN338N				800 N/mm <sup>2</sup>
1158	HSS	DIN338NSP				800 N/mm <sup>2</sup>
1108	HSS	DIN338NSP	TIN			1100 N/mm <sup>2</sup>
1102	HSS	DIN338W				AL
1103	HSS	DIN338H				CU
1105	HSSCO	DIN 338N				1100 N/mm <sup>2</sup>
1161	HSSCO	DIN338N	TIALN			1400 N/mm <sup>2</sup>
1107	HSSCO	DIN338N				1100 N/mm <sup>2</sup>
1106	HSSCO	DIN338IX				INOX
1162	HSSCO	DIN338IX	TIALN			INOX
1159	HSSCO	DIN338S				1100 N/mm <sup>2</sup>
1160	HSSCO	DIN338S	TIALN			1400 N/mm <sup>2</sup>
1110	WIDIA	DIN338N				1400 N/mm <sup>2</sup>
1109	HM-MD	DIN338N				1400 N/mm <sup>2</sup>
1163	HM-MD	DIN338N	TIALN			1400 N/mm <sup>2</sup>













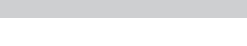

Brocas con mango cilíndrico largas / Forets à queue cylindrique longues / Long straight shank drill-bits / Brocas com manga cilíndrica compridas (DIN 340)

1112	HSS	DIN 340 N				800 N/mm <sup>2</sup>
1113	HSSCO	DIN 340 N				1100 N/mm <sup>2</sup>
1114	HSSCO	DIN 340 S				1100 N/mm <sup>2</sup>
1164	HSSCO	DIN 340 S	TIALN			1400 N/mm <sup>2</sup>



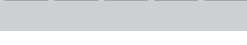



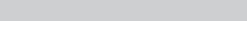



Brocas con mango cilíndrico extra largas / Forets à queue cylindrique extra longues / Extra-long straight shank drill-bits / Brocas com manga cilíndrica extra compridas (DIN 1869)

1115	HSS	DIN 1869 N				800 N/mm <sup>2</sup>
1165	HSSCO	DIN 1869 S				1100 N/mm <sup>2</sup>









Brocas con mango cilíndrico extra cortas / Forets à queue cylindrique extra-courtes / Extra-short straight shank drill-bits / Brocas com manga cilíndrica extra curtas (DIN 1897)

1116	HSS	DIN 1897 N				800 N/mm <sup>2</sup>
1117	HSS	DIN 1897 N				800 N/mm <sup>2</sup>
1118	HSSCO	DIN 1897 N				1100 N/mm <sup>2</sup>
1119	HSSCO	DIN 1897 N				1100 N/mm <sup>2</sup>
1166	HSSCO	DIN 1897 S				1100 N/mm <sup>2</sup>
1167	HSSCO	DIN 1897 S	TIALN			1400 N/mm <sup>2</sup>
1120	HD-MD	DIN 6539 N				1400 N/mm <sup>2</sup>
1168	HD-MD	DIN 6539 N	TIALN			1400 N/mm <sup>2</sup>















Brocas con mango cónico / Forets à queue conique / Taper straight shank drill-bits / Brocas com manga cônica

1121	HSS	DIN 345 N			800 N/mm <sup>2</sup>
1123	WIDIA	DIN 345 N			1400 N/mm <sup>2</sup>
1122	HSSCO	DIN 345 N			1100 N/mm <sup>2</sup>
1125	HSS	DIN 341 N			800 N/mm <sup>2</sup>
1126	HSS	DIN 1870 N			800 N/mm <sup>2</sup>







Brocas bidiametrales / Forets biétagés / Two-diameter drill-bits / Brocas bidiamétrais

1127	HSS	DIN 8376			800 N/mm <sup>2</sup>
1128	HSS	DIN 8374			800 N/mm <sup>2</sup>
1129	HSS	DIN 8377			800 N/mm <sup>2</sup>
1130	HSS	DIN 8375			800 N/mm <sup>2</sup>















Brocas de centrar / Forets à centrer / Centre drill-bits / Brocas de centrar

1131	HSS	DIN 333 A			800 N/mm <sup>2</sup>
1132	HSS	DIN 333 A			800 N/mm <sup>2</sup>
1133	HSS	DIN 333 A			800 N/mm <sup>2</sup>
1134	HSS	DIN 333 R			800 N/mm <sup>2</sup>
1135	HSS	DIN 333 R			800 N/mm <sup>2</sup>
1137	HSS	DIN 333 B			800 N/mm <sup>2</sup>
1138	HSSCO	CNC			1100 N/mm <sup>2</sup>

Brocas avellanadoras / Fraises coniques / Counterbore drill-bits / Brocas fresadoras

5101	HSS					800 N/mm <sup>2</sup>
5102	HSSCO					1100 N/mm <sup>2</sup>
5103	HSS		TIN			1100 N/mm <sup>2</sup>

Brocas escalonadas / Fraises étagées / Step drill-bits / Brocas escalonadas

5157	HSS					
5158	HSS		TIALN			
5105	HSS					800 N/mm <sup>2</sup>
5106	HSS		TIN			1100 N/mm <sup>2</sup>
5107	HSS	PGP				800 N/mm <sup>2</sup>
5108	HSS	PGC				800 N/mm <sup>2</sup>
5109	HSS					800 N/mm <sup>2</sup>
5112	HSS					

Brocas fresa / Forets fraiseur / Mill drills / Brocas fresa

5114	HSS					800 N/mm <sup>2</sup>
5115	HSS		TIN			1100 N/mm <sup>2</sup>



# ESCARIADO Y AVELLANADO / ALÉSAGE ET CHANFREINAGE REAMING AND COUNTERBORING / ESCAREAMENTO E FRESAGEM

## Escariadores de mano / Alésoirs à main / Hand reamers / Escareadores de mão

4101	HSS	DIN 206		Form. B 8° Tol. H7 ISO 236	800 N/mm <sup>2</sup>
4102	HSS	DIN 9		Form. B 8° 2% ISO 3465	800 N/mm <sup>2</sup>

## Escariadores de máquina / Alésoirs machine / Machine reamers / Escareadores de máquina

4104	HSSCO	DIN 212		Form. B 8° Tol. H7 ISO 521	1100 N/mm <sup>2</sup>
4105	HSSCO	DIN 212		Form. E 45° Tol. H7 ISO 521	1100 N/mm <sup>2</sup>
4103	HSSCO	DIN		Form. E 45° 2% ISO 3466	1100 N/mm <sup>2</sup>
4106	HSSCO	DIN 208		Form. B 8° Tol. H7 ISO 521	1100 N/mm <sup>2</sup>
4107	HSSCO	DIN 208		Form. C 45° Tol. H7 ISO 521	1100 N/mm <sup>2</sup>
4118	HM-MD	DIN 212		Form. B 8° Tol. H7 ISO 521	1400 N/mm <sup>2</sup>
4108	HSSCO	DIN 311		25° ISO 2238	800 N/mm <sup>2</sup>

## Escariadores de máquina entrada cónica / Alésoirs machine pour goupilles coniques / Machine reamers for taper holes / Escareadores de máquina entrada cónica

4115	HSSCO	DIN 212		45° 5%	800 N/mm <sup>2</sup>
4116	HSSCO	DIN 212		45° 8%	800 N/mm <sup>2</sup>
4117	HSSCO	DIN 212		45° 10%	800 N/mm <sup>2</sup>

## Escariadores huecos / Alésoirs creux finisseurs à machine / Hole machine reamers / Escareadores ocos

4109	HSSCO	DIN 219		Form. B 8° Tol. H7 ISO 2402	800 N/mm <sup>2</sup>
4114	HSS				

## Escariadores extensibles / Alésoirs extensibles / Extendable reamers / Escareadores extensíveis

4110	HSS			Form. A REFORZ. REINFORC. REINFORC.	800 N/mm <sup>2</sup>
4111	HSS			Form. A	800 N/mm <sup>2</sup>

Avellanadores / Fraises à trou et à chanfreiner / Countersink cutters / Escareadores cónicos

5116	HSS	DIN 335 C				3z	800 N/mm <sup>2</sup>
5117	HSSCO	DIN 335 C				3z	1100 N/mm <sup>2</sup>
5118	HSS	DIN 335 C	TIN			3z	1100 N/mm <sup>2</sup>
5119	HSSCO	DIN 335 C	TIN			3z	1400 N/mm <sup>2</sup>
5159	HD-MD	DIN 335 C				3z	1400 N/mm <sup>2</sup>
5120	HSS	DIN 335 C				3z	800 N/mm <sup>2</sup>
5121	HSS	DIN 335 C				3z	800 N/mm <sup>2</sup>
5122	HSS	DIN 335 C				3z	800 N/mm <sup>2</sup>
5123	HSS	DIN 334 C				3z	800 N/mm <sup>2</sup>
5124	HSS	DIN 335 C				3z	800 N/mm <sup>2</sup>
5125	HSS	DIN 335 C				1z	800 N/mm <sup>2</sup>
5126	HSS	DIN 334 A				z ≥ 4	800 N/mm <sup>2</sup>
5127	HSS	DIN 335 A				z ≥ 4	800 N/mm <sup>2</sup>
5129	HSS	DIN 335 D				3z	800 N/mm <sup>2</sup>

Avellanadores con agujero / Fraises à trou et à chanfreiner / Countersink cutters / Escareadores cónicos com orifício

5133	HSS						800 N/mm <sup>2</sup>
5134	HSSCO						1100 N/mm <sup>2</sup>
5135	HSS						800 N/mm <sup>2</sup>

Avellanadores Allen / Fraises à trou et à chanfreiner / Countersink cutters / Escareadores cónicos Allen

5136	HSS	DIN 373			ALLEN	ISO 4206	800 N/mm <sup>2</sup>
5137	HSS	DIN 375			ALLEN		800 N/mm <sup>2</sup>



# ROSCADO / TARAUDAGE / THREADING / ROSCAGEM

## Machos de mano / Tarauds à main / Hand taps / Machos de mão (M-MF)

2301	HSS	DIN 352 / 2181				800 N/mm <sup>2</sup>
2301/5	HSS	DIN 352				800 N/mm <sup>2</sup>
2302	HSS	DIN 352	TIN			800 N/mm <sup>2</sup>
2314	HSSE	DIN 352				1100 N/mm <sup>2</sup>
2303	HSSE	DIN 352	VAP			INOX

## Machos de mano / Tarauds à main / Hand taps / Machos de mão (BSW-BSF)

2304	HSS	DIN 352				800 N/mm <sup>2</sup>
2304/5	HSS	DIN 352				800 N/mm <sup>2</sup>
2305	HSS	DIN 2181				800 N/mm <sup>2</sup>

Machos de mano / Tarauds à main / Hand taps / Machos de mão (BSP)

2306	HSS	DIN 5157		G ISO 228	800 N/mm <sup>2</sup>
2306/5	HSS	DIN 5157		G ISO 228 LH 30°	800 N/mm <sup>2</sup>
2316	HSS	DIN 5157		G ISO 228	CU
2317	HSS	DIN 5157		G ISO 228 +0,1	CU

Machos de mano / Tarauds à main / Hand taps / Machos de mão (UNC-UNF-UN-BSPT-UNEF-BA-PG-NPT-NPTF-NPS-NPSF)

















2307	HSS	DIN 352		UNC REGIME B1.1 Tol. 2B	800 N/mm <sup>2</sup>
2307/5	HSS	DIN 352		UNC REGIME B1.1 Tol. 2B LH	800 N/mm <sup>2</sup>
2308	HSS	DIN 2181		UNF REGIME B1.1 Tol. 2B	800 N/mm <sup>2</sup>
2308/5	HSS	DIN 2181		UNF REGIME B1.1 Tol. 2B LH	800 N/mm <sup>2</sup>
2315	HSS	DIN 2181		UN REGIME B1.1 Tol. 2B	800 N/mm <sup>2</sup>
2309	HSS	DIN 5157		Rc DIN 2209	800 N/mm <sup>2</sup>

2310	HSS	DIN 2181			800 N/mm <sup>2</sup>
2311	HSS	DIN 352			800 N/mm <sup>2</sup>
2312	HSS	DIN 40432			800 N/mm <sup>2</sup>
2313	HSS				800 N/mm <sup>2</sup>
2318	HSS				800 N/mm <sup>2</sup>
2319	HSS				800 N/mm <sup>2</sup>
2320	HSS				800 N/mm <sup>2</sup>

Machos de máquina / Tarauds machine / Machine taps / Machos de máquina (M-MF)

2102	HSSE	DIN 371			800 N/mm <sup>2</sup>
2101	HSSE	DIN 376/374			800 N/mm <sup>2</sup>
2114	HSSE	DIN 371			800 N/mm <sup>2</sup>
2113	HSSE	DIN 376/374			800 N/mm <sup>2</sup>
2104	HSSE	DIN 371			800 N/mm <sup>2</sup>
2103	HSSE	DIN 376/374			800 N/mm <sup>2</sup>
2106	HSSE	DIN 371			800 N/mm <sup>2</sup>
2105	HSSE	DIN 376/374			800 N/mm <sup>2</sup>
2108	HSSE	DIN 371			800 N/mm <sup>2</sup>
2107	HSSE	DIN 376/374			800 N/mm <sup>2</sup>













Machos de máquina / Tardauds machine / Machine taps / Machos de máquina (BSW-BSF)

2136	HSSE	DIN 371		BSW BS 84	Form. C		R	800 N/mm <sup>2</sup>
2135	HSSE	DIN 376		BSW BS 84	Form. C		D	800 N/mm <sup>2</sup>
2138	HSSE	DIN 371		BSW BS 84	Form. B "Gun"		R	800 N/mm <sup>2</sup>
2137	HSSE	DIN 376		BSW BS 84	Form. B "Gun"		D	800 N/mm <sup>2</sup>
2140	HSSE	DIN 371		BSW BS 84	Form. C		35° R	800 N/mm <sup>2</sup>
2139	HSSE	DIN 376		BSW BS 84	Form. C		35° D	800 N/mm <sup>2</sup>
2141	HSSE	DIN 371		BSF BS 84	Form. C		R	800 N/mm <sup>2</sup>
2142	HSSE	DIN 376		BSF BS 84	Form. C		D	800 N/mm <sup>2</sup>

Machos de máquina / Tardauds machine / Machine taps / Machos de máquina (G ISO 228)

2144	HSSE	DIN 5156		G ISO 228	Form. C		D	800 N/mm <sup>2</sup>
2145	HSSE	DIN 5156		G ISO 228	Form. B "Gun"		D	800 N/mm <sup>2</sup>
2146	HSSE	DIN 5156		G ISO 228	Form. C		35° D	800 N/mm <sup>2</sup>



























Machos de máquina / Tardauds machine / Machine taps / Machos de máquina (UNC)

2148	HSSE	DIN 371		UNC ANSI B1.1	Form. C		Tol. 2B R	800 N/mm <sup>2</sup>
2147	HSSE	DIN 376		UNC ANSI B1.1	Form. C		Tol. 2B D	800 N/mm <sup>2</sup>
2150	HSSE	DIN 371		UNC ANSI B1.1	Form. B "Gun"		Tol. 2B R	800 N/mm <sup>2</sup>
2149	HSSE	DIN 376		UNC ANSI B1.1	Form. B "Gun"		Tol. 2B D	800 N/mm <sup>2</sup>
2152	HSSE	DIN 371		UNC ANSI B1.1	Form. C		Tol. 2B 35° R	800 N/mm <sup>2</sup>
2151	HSSE	DIN 376		UNC ANSI B1.1	Form. C		Tol. 2B 35° D	800 N/mm <sup>2</sup>









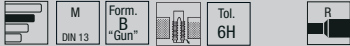

Machos de máquina / Tarauds machine / Machine taps / Machos de máquina (UNF)

2154	HSSE	DIN 371		UNF ANSI B1.1	Form. C		Tol. 2B		R	800 N/mm <sup>2</sup>
2153	HSSE	DIN 374		UNF ANSI B1.1	Form. C		Tol. 2B		D	800 N/mm <sup>2</sup>
2156	HSSE	DIN 371		UNF ANSI B1.1	Form. B "Gun"		Tol. 2B		R	800 N/mm <sup>2</sup>
2155	HSSE	DIN 374		UNF ANSI B1.1	Form. B "Gun"		Tol. 2B		D	800 N/mm <sup>2</sup>
2158	HSSE	DIN 371		UNF ANSI B1.1	Form. C		Tol. 2B		R	800 N/mm <sup>2</sup>
2157	HSSE	DIN 374		UNF ANSI B1.1	Form. C		Tol. 2B		D	800 N/mm <sup>2</sup>













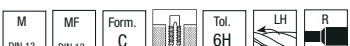

Machos de máquina / Tarauds machine / Machine taps / Machos de máquina (UN-BSPT-UNEF-BA-PG-NPT-NPTF-NPS-NPSF-TR)

2189	HSSE	DIN 374		UN ANSI B1.1	Form. C		Tol. 2B		D	800 N/mm <sup>2</sup>
2143	HSSE	DIN 374		UNS ANSI B1.1	Form. C		Tol. 2B		D	800 N/mm <sup>2</sup>
2159	HSSE	DIN 5156		Rc DIN 9136	Form. C				D	800 N/mm <sup>2</sup>
2160	HSSE	DIN 374		UNEF ANSI B1.1	Form. C		Tol. 2B		D	800 N/mm <sup>2</sup>
2162	HSSE	DIN 371		BA BS 93	Form. C		BSB 93		R	800 N/mm <sup>2</sup>
2163	HSSE	DIN 40433		PG DIN 6483	Form. C				D	800 N/mm <sup>2</sup>
2164	HSSE	DIN 374		NPT ANSI B1.1	Form. C		Tol. 6H		D	800 N/mm <sup>2</sup>
2209	HSSE	DIN 374		NPTF ANSI B1.201	Form. C		Tol. 6H		D	800 N/mm <sup>2</sup>
2210	HSSE	DIN 374		NPS ANSI B1.201	Form. C		Tol. 6H		D	800 N/mm <sup>2</sup>
2211	HSSE	DIN 374		NPSF ANSI B1.201	Form. C		Tol. 6H		D	800 N/mm <sup>2</sup>
2212	HSSE			Tr DIN 1103			Tol. 7H			800 N/mm <sup>2</sup>

Machos de máquina especiales / Tarauds machine spéciaux / Special machine taps / Machos de máquina especiais

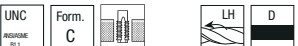
2111	HSSE	DIN 371-L			800 N/mm <sup>2</sup>
2112	HSSE	DIN 371-L			800 N/mm <sup>2</sup>
2127	HSSE	DIN 371			800 N/mm <sup>2</sup>
2199	HSSE	DIN 357			800 N/mm <sup>2</sup>
2134	HSSE	DIN 357			800 N/mm <sup>2</sup>
2806	HSSE	DIN 13			800 N/mm <sup>2</sup>

Machos de máquina izquierdas / Tarauds machine à gauche / Left hand machine taps / Machos de máquina esquerda

2101/5	HSSE	DIN 376/374			800 N/mm <sup>2</sup>
2102/5	HSSE	DIN 371			800 N/mm <sup>2</sup>
2135/5	HSSE	DIN 376			800 N/mm <sup>2</sup>
2136/5	HSSE	DIN 371			800 N/mm <sup>2</sup>
2144/5	HSSE	DIN 5156			800 N/mm <sup>2</sup>
2147/5	HSSE	DIN 376			800 N/mm <sup>2</sup>
2153/5	HSSE	DIN 374			800 N/mm <sup>2</sup>
2212/5	HSSE				800 N/mm <sup>2</sup>

Machos de máquina tolerancias especiales / Tarauds machine tolérances spéciales / Special tolerances machine taps / Machos de máquina tolerâncias especiais

2110	HSSE	DIN 371			M DIN 13	Form. B "Gun"	Tol. 6H +0,1	R	800 N/mm <sup>2</sup>
2109	HSSE	DIN 376			M DIN 13	Form. B "Gun"	Tol. 6H +0,1	D	800 N/mm <sup>2</sup>
2166	HSSE	DIN 371			M DIN 13	Form. C	Tol. 6H +0,1	35° R	800 N/mm <sup>2</sup>
2165	HSSE	DIN 376			M DIN 13	Form. C	Tol. 6H +0,1	35° D	800 N/mm <sup>2</sup>
2168	HSSE	DIN 371			M DIN 13	Form. B "Gun"	Tol. 6G	R	800 N/mm <sup>2</sup>
2169	HSSE	DIN 376			M DIN 13	Form. B "Gun"	Tol. 6G	D	800 N/mm <sup>2</sup>
2170	HSSE	DIN 371			M DIN 13	Form. C	Tol. 6G	35° R	800 N/mm <sup>2</sup>
2208	HSSE	DIN 376			M DIN 13	Form. C	Tol. 6G	35° D	800 N/mm <sup>2</sup>

Machos de máquina de laminación / Tarauds machine à refouler / Roll machine taps / Machos de máquina de laminação

2131	HSSEX	DIN 371	AlCrN		M DIN 13	Form. C	Tol. 6HX	R	800 N/mm <sup>2</sup>
2130	HSSEX	DIN 376	AlCrN		M DIN 13	Form. C	Tol. 6HX	D	800 N/mm <sup>2</sup>
2188	HSSEX	DIN 371	TiN		M DIN 13	Form. C	Tol. 6HX	R	1100 N/mm <sup>2</sup>
2187	HSSEX	DIN 376	TiN		M DIN 13	Form. C	Tol. 6HX	D	1100 N/mm <sup>2</sup>
2198	HSSEX	DIN 371	AlCrN		M DIN 13	Form. C	Tol. 6HX	R	800 N/mm <sup>2</sup>
2197	HSSEX	DIN 376	AlCrN		M DIN 13	Form. C	Tol. 6HX	D	800 N/mm <sup>2</sup>
2214	HSSEX	DIN 371	TiN		M DIN 13	Form. C	Tol. 6HX	R	1100 N/mm <sup>2</sup>
2213	HSSEX	DIN 376	TiN		M DIN 13	Form. C	Tol. 6HX	D	1100 N/mm <sup>2</sup>

2200	HSSEX	DIN 371	AlCrN		M DIN 13	Form. C	Tol. 6GX	R	800 N/mm2
2201	HSSEX	DIN 376	AlCrN		M DIN 13	Form. C	Tol. 6GX	D	800 N/mm2
2216	HSSEX	DIN 371	TIN		M DIN 13	Form. C	Tol. 6GX	R	1100 N/mm2
2215	HSSEX	DIN 376	TIN		M DIN 13	Form. C	Tol. 6GX	D	1100 N/mm2
2202	HSSEX	DIN 371	AlCrN		M DIN 13	Form. C	Tol. 6GX	R	800 N/mm2
2203	HSSEX	DIN 376	AlCrN		M DIN 13	Form. C	Tol. 6GX	D	800 N/mm2
2218	HSSEX	DIN 371	TIN		M DIN 13	Form. C	Tol. 6GX	R	1100 N/mm2
2217	HSSEX	DIN 376	TIN		M DIN 13	Form. C	Tol. 6GX	D	1100 N/mm2

Machos de máquina alto rendimiento / Tarauds machine haut rendement / High performance machine taps / Machos de máquina alto rendimento





2116	HSSE	DIN 371	TIN		M DIN 13	Form. B "Gun"	Tol. 6H	R	1100 N/mm2
2115	HSSE	DIN 376	TIN		M DIN 13	Form. B "Gun"	Tol. 6H	D	1100 N/mm2
2118	HSSE	DIN 371	TIN		M DIN 13	Form. C	Tol. 6H	35° R	1100 N/mm2
2117	HSSE	DIN 376	TIN		M DIN 13	Form. C	Tol. 6H	35° D	1100 N/mm2
2171	HSSE	DIN 371	TiCN		M DIN 13	Form. B "Gun"	Tol. 6H	R	1100 N/mm2
2172	HSSE	DIN 376	TiCN		M DIN 13	Form. B "Gun"	Tol. 6H	D	1100 N/mm2
2173	HSSE	DIN 371	TiCN		M DIN 13	Form. C	Tol. 6H	35° R	1100 N/mm2
2174	HSSE	DIN 376	TiCN		M DIN 13	Form. C	Tol. 6H	35° D	1100 N/mm2

2129	HSSE	DIN 371	NIT		M DIN 13	Form. C	Tol. 6HX	R	○	F
2128	HSSE	DIN 376	NIT		M DIN 13	Form. C	Tol. 6HX	D	○	F
2180	HSSE	DIN 371	TiCN		M DIN 13	Form. C	Tol. 6HX	R	○	F
2179	HSSE	DIN 376	TiCN		M DIN 13	Form. C	Tol. 6HX	D	○	F
2133	HSSE	DIN 371			M DIN 13	Form. B "Gun"	Tol. 6H	R	○	AL
2132	HSSE	DIN 376			M DIN 13	Form. B "Gun"	Tol. 6H	D	○	AL
2182	HSSE	DIN 371			M DIN 13	Form. C	Tol. 6HX	45° R	○	AL
2181	HSSE	DIN 376			M DIN 13	Form. C	Tol. 6HX	45° D	○	AL
2184	HSSE	DIN 371	CrN		M DIN 13	Form. B "Gun"	Tol. 6H	R	○	AL
2183	HSSE	DIN 376	CrN		M DIN 13	Form. B "Gun"	Tol. 6H	D	○	AL
2186	HSSE	DIN 371	CrN		M DIN 13	Form. C	Tol. 6H	45° R	○	AL
2185	HSSE	DIN 376	CrN		M DIN 13	Form. C	Tol. 6H	45° D	○	AL
2190	HSSE	DIN 371			M DIN 13	Form. E	Tol. 6H	R	○	CU
2191	HSSE	DIN 376			M DIN 13	Form. E	Tol. 6H	D	○	CU
2192	HSSE	DIN 5156			G ISO 228	Form. E	Tol. 6H	D	○	CU
2206	HSSE	DIN 5156			G ISO 228	Form. E	Tol. 6H	+0,1 D	○	CU

2126	HSSEX	DIN 371	TICN		
2125	HSSEX	DIN 376	TICN		
2124	HSSEX	DIN 371	TICN		
2123	HSSEX	DIN 376	TICN		
2176	HSSEX	DIN 371	TICN		
2175	HSSEX	DIN 376	TICN		
2178	HSSEX	DIN 371	TICN		
2177	HSSEX	DIN 376	TICN		
2122	HSSE	DIN 371	VAP		
2121	HSSE	DIN 376	VAP		
2120	HSSE	DIN 371	VAP		
2119	HSSE	DIN 376	VAP		
2219	HSSE	DIN 371	TIN		
2220	HSSE	DIN 376	TIN		
2221	HSSE	DIN 371	TIN		
2222	HSSE	DIN 376	TIN		

Cojinetes / Filières / Dies / Caçonetes





2501	HSS	DIN EN22568			MF DIN 13	Tol. 6g				
2501/5	HSS	DIN EN22568			M DIN 13	MF DIN 13	Tol. 6g			
2514	HSSE	DIN EN22568	NIT		M DIN 13	MF DIN 13	Tol. 6g			
2512	HSSE	DIN EN22568	VAP		M DIN 13		Tol. 6g			
2502	HSS	DIN EN22568			BSW BS 84					
2502/5	HSS	DIN EN22568			BSW BS 84					
2503	HSS	DIN EN22568			BSF BS 84					
2504	HSS	DIN EN24231			G ISO 228					
2504/5	HSS	DIN EN24231			G ISO 228					
2522	HSS	DIN EN24231			G ISO 228	Form. A				
2521	HSS	DIN EN24231			G ISO 228		+0,1			
2505	HSS	DIN EN22568			UNC ANSI B1.1		Tol. 2A			
2505/5	HSS	DIN EN22568			UNC ANSI B1.1		Tol. 2A			
2506	HSS	DIN EN22568			UNF ANSI B1.1		Tol. 2A			
2506/5	HSS	DIN EN22568			UNF ANSI B1.1		Tol. 2A			
2507	HSS	DIN EN24230			R DIN 2209					
2508	HSS	DIN EN22568			UNEF ANSI B1.1		Tol. 2A			
2520	HSS	DIN EN22568			UN ANSI B1.1		Tol. 2A			
2510	HSS	DIN 40434			PG DIN 40434					
2523	HSS	DIN EN2256			BA BS 93					

2509	HSS	DIN EN24230		NPT ANSI B1.201	800 N/mm <sup>2</sup>
2524	HSS	DIN EN24230		NPTF ANSI B1.201	800 N/mm <sup>2</sup>
2525	HSS	DIN EN24230		NPS ANSI B1.201	800 N/mm <sup>2</sup>
2526	HSS	DIN EN24230		NPSF ANSI B1.201	800 N/mm <sup>2</sup>



**Machos máquina para insertos / Tarauds machine pour inserts / Machine taps for wire thread inserts / Machos máquina para insertos**

2701	HSS	ISO 529		M DIN 13 Form. D	800 N/mm <sup>2</sup>
2702	HSS	ISO 529		UNC ANSI B1.1 Form. D	800 N/mm <sup>2</sup>
2703	HSS	ISO 529		UNF ANSI B1.1 Form. D	800 N/mm <sup>2</sup>
2704	HSS	ISO 529		BSW BS 84 Form. D	800 N/mm <sup>2</sup>

**Insertos roscados / Filets rapportés / Wire thread inserts / Insertos roscados**

















2705	HSS	DIN 8140		M DIN 13 Tol. 6H	800 N/mm <sup>2</sup>
2706	HSS	DIN 8140		UNC ANSI B1.1 Tol. 2B	800 N/mm <sup>2</sup>
2707	HSS	DIN 8140		UNF ANSI B1.1 Tol. 2B	800 N/mm <sup>2</sup>
2708	HSS	DIN 8140		BSW BS 84 Tol. 2B	800 N/mm <sup>2</sup>

**Accesorios / Accessoires / Accessories / Acessórios**

2709	Insertador / Appareil de pose manuel / Insert Tool / Insensor				
2710	Rompe Arrastre / Rupteur / Tang break tool / Corte de arrasto				

**Calibres / Calibres / Gauges / Calibres**

2901/1	ISO 1502		CTPNP DIN 13 M DIN 13 MF DIN 13 Tol. 6H PASA NO PASA	
2901/4	ISO 1502		CTP DIN 13 M DIN 13 MF DIN 13 Tol. 6H PASA	
2901/5	ISO 1502		CTNP DIN 13 M DIN 13 MF DIN 13 Tol. 6H NO PASA	
2901/2	ISO 1502		CAP DIN 13 M DIN 13 MF DIN 13 Tol. 6G PASA	

2901/3	ISO 1502		CANP M DIN 13 MF DIN 13 Tol. 6G NO PASA
2902/1	ISO 228-2		CTPNP G ISO 228 PASA NO PASA
2902/4	ISO 228-2		CTP G ISO 228 PASA
2902/5	ISO 228-2		CTNP G ISO 228 NO PASA
2902/2	ISO 228-2		CAP G ISO 228 PASA
2902/3	ISO 228-2		CANP G ISO 228 NO PASA
2903/1	BS 919		CTPNP BSW BS 84 PASA NO PASA
2903/2	BS 919		CAP BSW BS 84 PASA
2903/3	BS 919		CANP BSW BS 84 NO PASA
2904/1	ANSI / ASME B1.2		CTPNP UNC ANSI/ASME B1.2 PASA NO PASA
2904/2	ANSI / ASME B1.2		CAP UNC ANSI/ASME B1.2 PASA
2904/3	ANSI / ASME B1.2		CANP UNC ANSI/ASME B1.2 NO PASA
2905/1	ANSI / ASME B1.2		CTPNP UNF ANSI/ASME B1.2 PASA NO PASA
2905/2	ANSI / ASME B1.2		CAP UNF ANSI/ASME B1.2 PASA
2905/3	ANSI / ASME B1.2		CANP UNF ANSI/ASME B1.2 NO PASA
2906/1	ANSI / ASME B1.20.1		CTPNP NPT ANSI/ASME B1.2 PASA NO PASA
2906/2	ANSI / ASME B1.20.1		CAPNP NPT ANSI/ASME B1.2 PASA NO PASA
2907/1	DIN 7162		CTL PASA NO PASA
2907/4	DIN 7162		CTLP H7 PASA
2907/5	DIN 7162		CTLNP H7 NO PASA
2907/2	DIN 2250-C		CAL



# FRESADO / FRAISAGE / MILLING / FRESAGEM













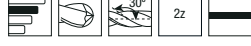

## Fresas un corte / Fraises 1 z / 1 z mills / Fresas um corte

3120	HSS					1z	AL
3121	HSS					1z	AL
3122	HSS					1z	AL
3141	HM-MD		TIALN			1z	AL



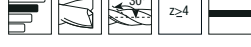







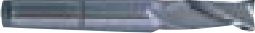



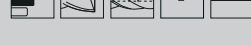

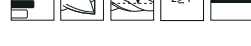

## Fresas HSSE mango cilíndrico cortas / Fraises HSSE queue cylindrique courtes / HSSE Straight short shank mills / Fresas HSSE manga cilíndrica curtas

3110	HSSE	DIN 327 N				2z	1100 N/mm <sup>2</sup>
3110/1	HSSE	DIN 327 N	TIALN			2z	1400 N/mm <sup>2</sup>
3112	HSSE	DIN 327 N				2z	1100 N/mm <sup>2</sup>
3112/1	HSSE	DIN 327 N	TIALN			2z	1400 N/mm <sup>2</sup>
3114	HSSE	DIN 844 W				3z	INOX
3114/1	HSSE	DIN 844 W	TIALN			3z	INOX
3115	HSSE	DIN 844 N				z≥4	1100 N/mm <sup>2</sup>
3115/1	HSSE	DIN 844 N	TIALN			z≥4	1400 N/mm <sup>2</sup>
3117	HSSE	DIN 844 NR				z≥4	1100 N/mm <sup>2</sup>
3117/1	HSSE	DIN 844 NR	TIALN			z≥4	1400 N/mm <sup>2</sup>
3119	HSSE	DIN 844 NRF				z≥4	1100 N/mm <sup>2</sup>
3119/1	HSSE	DIN 844 NRF	TIALN			z≥4	1400 N/mm <sup>2</sup>

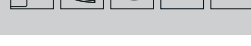

Fresas HSSE mango cilíndrico largas / Fraises HSSE queue cylindrique longues / HSSE Straight long shank mills / Fresas HSSE manga cilíndrica compridas

3111	HSSE	DIN 844				1100 N/mm <sup>2</sup>
3111/1	HSSE	DIN 844	TIALN			1400 N/mm <sup>2</sup>
3113	HSSE	DIN 844				1100 N/mm <sup>2</sup>
3113/1	HSSE	DIN 844	TIALN			1400 N/mm <sup>2</sup>
3116	HSSE	DIN 844 N				1100 N/mm <sup>2</sup>
3116/1	HSSE	DIN 844 N	TIALN			1400 N/mm <sup>2</sup>
3118	HSSE	DIN 844 NR				1100 N/mm <sup>2</sup>
3118/1	HSSE	DIN 844 NR	TIALN			1400 N/mm <sup>2</sup>













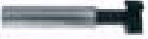

Fresas mango cónico / Fraises queue conique / Tapered shank mills / Fresas manga cónica

3144	HSSE	DIN 326 D				1100 N/mm <sup>2</sup>
3144/1	HSSE	DIN 326 D	TIALN			1400 N/mm <sup>2</sup>
3145	HSSE	DIN 845 B				1100 N/mm <sup>2</sup>
3145/1	HSSE	DIN 845 B	TIALN			1400 N/mm <sup>2</sup>
3146	HSSE	DIN 845 B				1100 N/mm <sup>2</sup>
3146/1	HSSE	DIN 845 B	TIALN			1400 N/mm <sup>2</sup>
3147	HSSE	DIN 845 B				1100 N/mm <sup>2</sup>
3147/1	HSSE	DIN 845 B	TIALN			1400 N/mm <sup>2</sup>
3148	HSSE	DIN 845 B				1100 N/mm <sup>2</sup>
3148/1	HSSE	DIN 845 B	TIALN			1400 N/mm <sup>2</sup>

Fresas con agujero / Fraises à trou / Mills with holes / Fresas com orifício

3149	HSSE	DIN 1880 N			 	
3150	HSSE	DIN 1880 NR			 	
3151	HSSE	DIN 885 D				























Fresas HSSE especiales / Fraises HSSE spéciales / HSSE Special mills / Fresas HSSE especiais

3152	HSSE	DIN 850 D				
3153	HSSE	DIN 851 N			 ISO 3337	
3154	HSSE	DIN 851 B			 ISO 1641	
3155	HSSE	DIN 1833 A			 ISO 3859	
3156	HSSE	DIN 1833 B			 ISO 3859	

Fresas HSSEX (ASP) / Fraises HSSEX (ASP) / HSSEX special mills / Fresas HSSEX (ASP)

3157	HSSEX	DIN 844NR			   	
3158	HSSEX	DIN 844NR			   	
3159	HSSEX	DIN 844NRF			   	
3160	HSSEX	DIN 844NRF			   	











































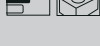

Fresas metal duro K30 / Fraises métal dur K30 / K30 Hard metal mills / Fresas metal duro K30

3101	HM-MD				  	
3101/1	HM-MD				  	
3103	HM-MD				  	
3103/1	HM-MD				  	

3105	HM-MD					1400 N/mm <sup>2</sup>
3105/1	HM-MD		TIALN			1400 N/mm <sup>2</sup>
3106	HM-MD	DIN 6527				INOX
3106/1	HM-MD	DIN 6527	TIALN			INOX
3107	HM-MD					1400 N/mm <sup>2</sup>
3107/1	HM-MD		TIALN			1400 N/mm <sup>2</sup>
3102	HM-MD					1400 N/mm <sup>2</sup>
3102/1	HM-MD		TIALN			1400 N/mm <sup>2</sup>
3104	HM-MD					1400 N/mm <sup>2</sup>
3104/1	HM-MD		TIALN			1400 N/mm <sup>2</sup>

Fresas rotativas metal duro / Fraises rotatives métal dur / Hard metal rotary mills / Fresas rotativas metal duro

3201	HM-MD	Cilíndrica Cylindrique Straight Cilíndrica				1100 N/mm <sup>2</sup>
3202	HM-MD	Cilíndrica con corte Cylindrique taillée Straight with cut Cilíndrica con corte				1100 N/mm <sup>2</sup>
3203	HM-MD	Cilíndrica radio Cylindrique à rayon Straight radius Cilíndrica raio				1100 N/mm <sup>2</sup>
3204	HM-MD	Esférica Sphérique Spherical Esférica				1100 N/mm <sup>2</sup>
3205	HM-MD	Oval Ovale Oval Oval				1100 N/mm <sup>2</sup>
3206	HM-MD	Árbol con radio Arbre à rayon Arc with radius Árvore com raio				1100 N/mm <sup>2</sup>
3207	HM-MD	Árbol Arbre Arc Árvore				1100 N/mm <sup>2</sup>
3208	HM-MD	Llama Flamme Flame Chama				1100 N/mm <sup>2</sup>
3209	HM-MD	Cónica Conique Tapered Cónica				1100 N/mm <sup>2</sup>
3210	HM-MD	Cónica 90° Conique 90° Tapered 90° Cónica 90°				1100 N/mm <sup>2</sup>

3211	HM-MD	Cónica radio Conique à rayon Tapered radius Cónica raio		 	1100 N/mm <sup>2</sup>
3212	HM-MD	Cono invertido Cône inversé Inverted taper Cone invertido		 	1100 N/mm <sup>2</sup>
3213	HM-MD	Canto Disque Disk Canto		 	1100 N/mm <sup>2</sup>
3214	HM-MD	Cilíndrica L Cylindrique L Straight L Cilíndrica L		 	1100 N/mm <sup>2</sup>
3215	HM-MD	Cilíndrica con corte L Cylindrique taillée L Straight with L cut Cilíndrica com corte L		 	1100 N/mm <sup>2</sup>
3216	HM-MD	Cilíndrica radio L Cylindrique à rayon L Straight L radius Cilíndrica rádio L		 	1100 N/mm <sup>2</sup>
3217	HM-MD	Árbol L Arbre L L Arc Árvore L		 	1100 N/mm <sup>2</sup>
3218	HM-MD	Esférica L Sphérique L L Spherical Esférica L		 	1100 N/mm <sup>2</sup>
3219	HM-MD	Árbol radio L Arbre à rayon L L Radius arc Árvore raio L		 	1100 N/mm <sup>2</sup>
3201/1	HM-MD	Cilíndrica Cylindrique Straight Cilíndrica		 	AL
3202/1	HM-MD	Cilíndrica con corte Cylindrique taillée Straight with cut Cilíndrica com corte		 	AL
3203/1	HM-MD	Cilíndrica radio Cylindrique à rayon Straight radius Cilíndrica raio		 	AL
3204/1	HM-MD	Esférica Sphérique Spherical Esférica		 	AL
3206/1	HM-MD	Árbol radio Arbre à rayon Arc radius Árvore raio		 	AL
3211/1	HM-MD	Cónica con radio Conique à rayon Tapered with radius Cónica com raio		 	AL



**Hepryc<sub>RF</sub>**

CUTTING TECHNOLOGIES

[www.heprycrf.com](http://www.heprycrf.com)